

FIBERGLASS BRINER: TYPICAL ORIENTATION

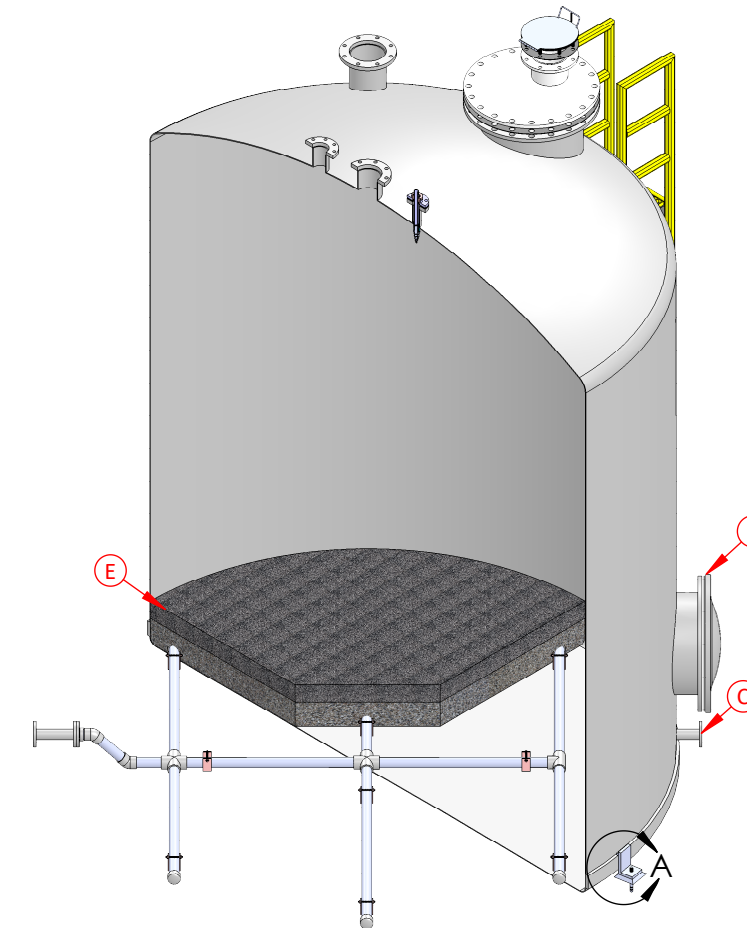

1) Since anchor lugs are independent, they can be located as necessary... basic spacing must be maintained to meet design requirements of jobsite location.
2) Grout lug as shown.

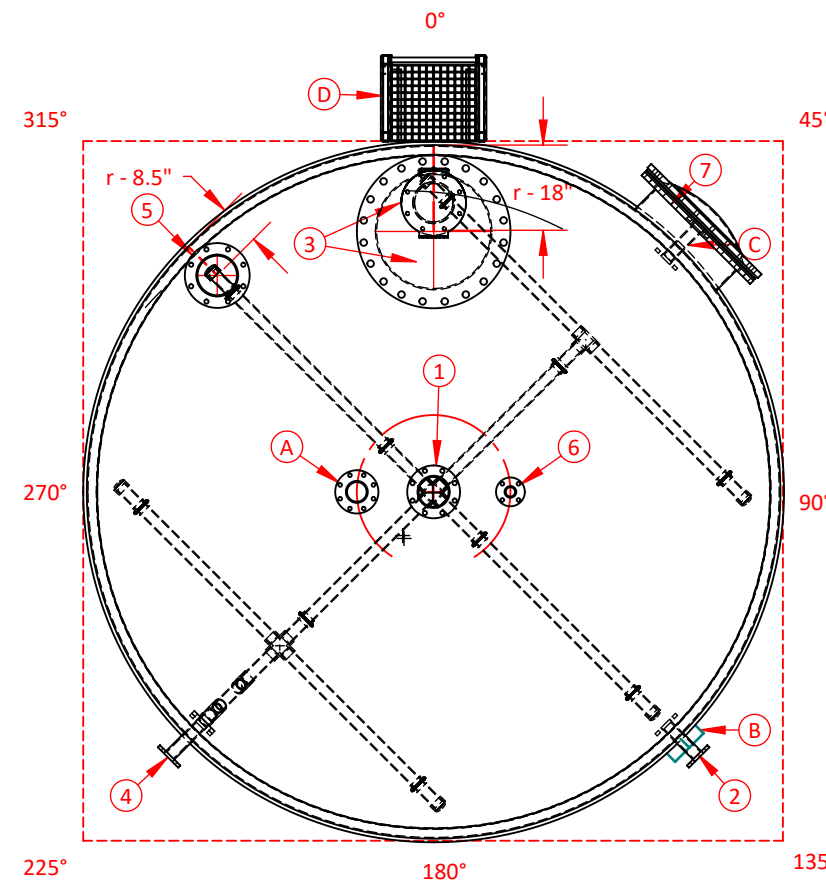
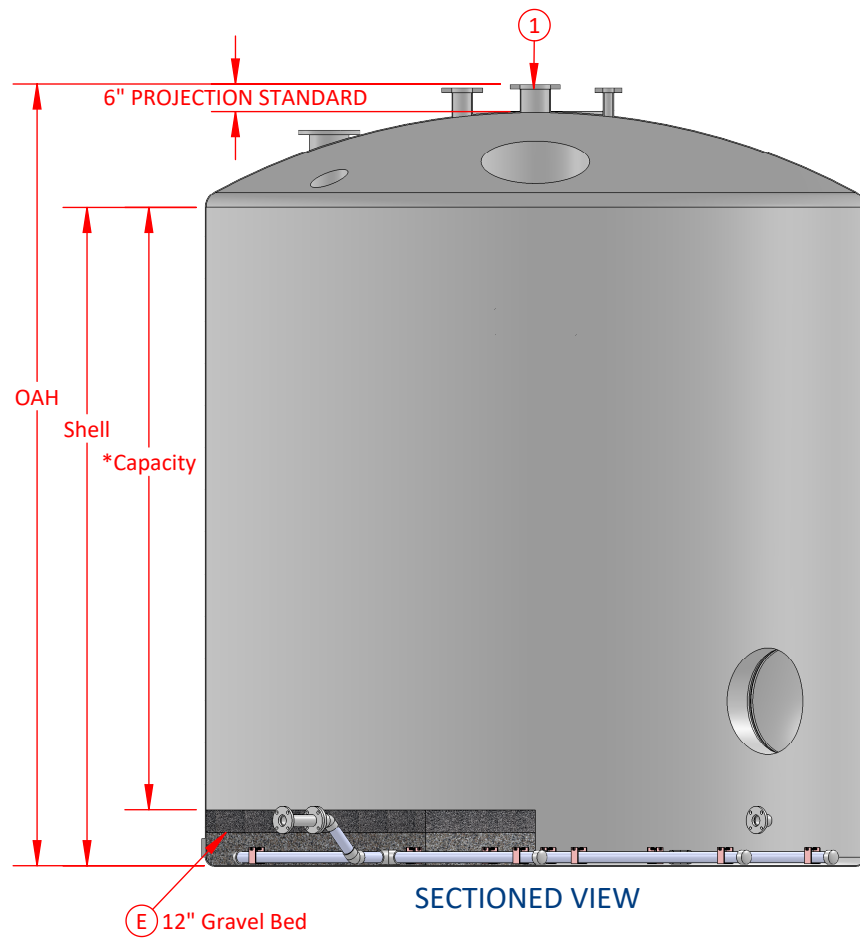
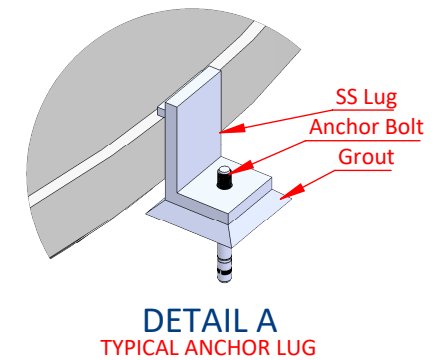

*CAPACITY (TONS)	CAPACITY (CuFt)	ID	SHELL	OAH
5	147	5'	8' 6"	10'
10	289	6'	11' 3"	13'
15	432	7'	12' 3"	14' 1"
20	578	8'	12' 6"	13' 6"
25	903	10'	10' 3"	12' 6"
30	864	10'	12'	14' 3"
35	1,001	10'	13' 9"	16'
40	1,138	10'	15' 6"	17' 9"
45	1,300	12'	12' 6"	15' 1"
50	1,442	12'	13' 9"	16' 4"
55	1,583	12'	15'	17' 7"
60	1,724	12'	16' 3"	18' 10"
65	1,866	12'	17' 6"	20' 1"
70	2,007	12'	18' 9"	21' 4"
75	2,149	12'	20'	22' 7"

*Based on salt with a density of 70#/CuFt

MARK	DEGREES	RADIUS	HEIGHT	SIZE	CONNECTION	FUNCTION
STANDARD FEATURES						
1	TDC	---	---	6"	FLANGE	SALT LOADING POINT for 4" 304SS Fill Line + Pipe Supports @ 247.5°
2	225°	---	10"	2"	DOUBLE FLANGE	BRINE OUTLET with Internal Collection Plenum
3	0°	r - 18"	---	24"	FLANGE	MANWAY is 304SS/Neoprene and 8" SS Hinged Pressure Relief / Inspection Port
4	135°	---	10"	2"	DOUBLE FLANGE	DRAIN with Internal Driptube (to 1" off floor) and Screen
5	315°	r - 8.5"	---	8"	FLANGE	VENT + Pipe Supports at 315°
6	90°	16"	---	2"	FLANGE	WATER INLET with removable 1" Water Distribution Head + Pipe Supports
7	45°	---	36"	24"	FLANGE	SIDE MANWAY with 304SS Hardware and Neoprene Gasket
OPTIONS						
A	270°	16"	---	4"	FLANGE	SALT LEVEL INDICATOR
B	135°	---	66"	---	---	FREEZE PROTECTION SYSTEM CONTROL
C	45°	---	10"	2"	DOUBLE FLANGE	LEVEL CONTROL SENSOR
D	0°	---	---	---	---	FIBERGLASS ACCESS LADDER with OPERATOR SAFETY DECK (OTHER DESIGNS AVAILABLE)
E	360°	r	12"	---	---	GRAVEL FILTRATION BED: 7" of 1/2 x 1/4 and 5" of 1/4 x 1/8 NSF/AWWA Washed Quartz

NOT SHOWN HERE: 304SS LIFTING LUGS

NOTE: Connections can be oriented to meet jobsite-specific requirements / Connections as shown are oriented to minimize shipping dimensions

OTHER OPTIONS: NSF Resins / RTP-1 Label / Food Grade Resins with Post Cure / Double Wall / Full array of testing reports / Secondary loading method

